

# Sweepers for tractors and municipal vehicles

## KM 50

Working widths  
130/147/165 cm

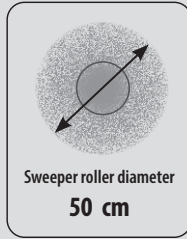

### Sweeping roller versions

Combination sweeper roller (1), poly-corrugated wire sweeper roller (2), Dirt sweeper roller (3), Snow sweeper roller (4)  
Other roller types for different applications possible.



Parking supports



Chain case with maintenance-free chain tensioner



Bolted Attachment frame with perforated strip



Protected positioned Hydraulic motor

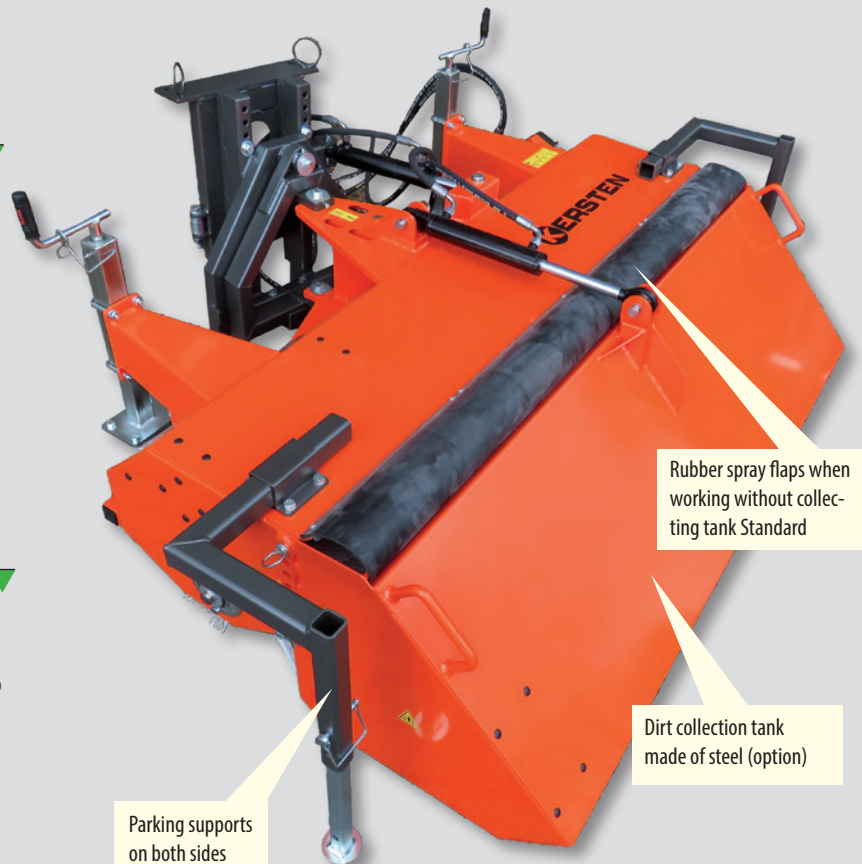

Hydraulic  
Lateral adjustment

Hydraulic  
Container emptying

Stepless  
Height adjustment  
of the sweeper

Sturdy wheels

## FACTS

### Use

#### Sweeper roller types

- **Combination sweeper roller**  
(standard factory setting)  
For over 90% of all applications
- **Poly-corrugated wire sweeping roller**  
For high levels of stubborn dirt, e.g. moss etc.
- **Dirt sweeping roller**  
Suitable for larger amounts of dirt due to
- **Snow sweeping roller**  
A special bristle arrangement with a larger the snow is optimally transported away.

#### Practical accessories

- **Dirt collection container**  
The sweepings are collected in one operation
- **Rubber spray flap**  
To reduce flying dirt particles
- **Side broom**  
For collecting dirt even in side areas, z. e.g. kerb gutters etc.
- **Parking supports**  
For longer storage in order not to damage the sweeping roller

Hydraulic  
Container emptying



Stepless  
Height adjustment  
of the sweeper



Pendulum compensation  
for optimal  
Ground adaptation



Measurements	KM 13050 M	KM 14750 M	KM 16550 M	KM 13050 H	KM 14750 H	KM 16550 H
A: Working width straight; without side broom [cm]	130	147	165	130	147	165
B: Working width straight; with side broom [cm]	153	170	188	153	170	188
Working width sloping [cm]	118	134	150	118	134	150
C: Straight passage width; without side brushes [cm]	142	159	177	142	159	177
D: Straight passage width; with side brushes [cm]	148	165	183	148	165	183
Clearance width sloping; without SSB [cm]	138	155	173	138	155	173
E: Length; including SSB; without attachment frame [cm]	137	137	137	137	137	137
F: Length; without SSB; without attachment frame [cm]	86	86	86	86	86	86
G: Height; without attachment frame [cm]	82	82	82	82	82	82
Brush diameter [cm]	50	50	50	50	50	50
Swivel angle [degrees]	24	24	24	24	24	24
Sweeping mirror [cm]	8-10	8-10	8-10	8-10	8-10	8-10
<b>Weights</b>						
Basic unit [kg]	162	175	185	162	175	185
Collecting container [kg]	67	73	80	67	73	80
Side brushes [kg]	40	40	40	40	40	40
Water sprinkler 100 litres ; full tanks [kg]	126	126	126	126	126	126
<b>Volume</b>						
Collection tank [ltr]	95	102	115	95	102	115
Water sprinkler [ltr]	100	100	100	100	100	100
<b>Capacity</b>						
Oil volume [ltr/min] at 180 bar	35	35	35	35	35	35
Tractor power [hp]	25	25	25	25	25	25

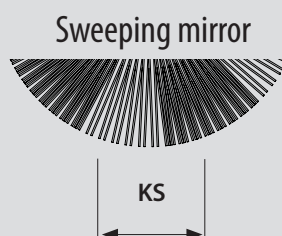
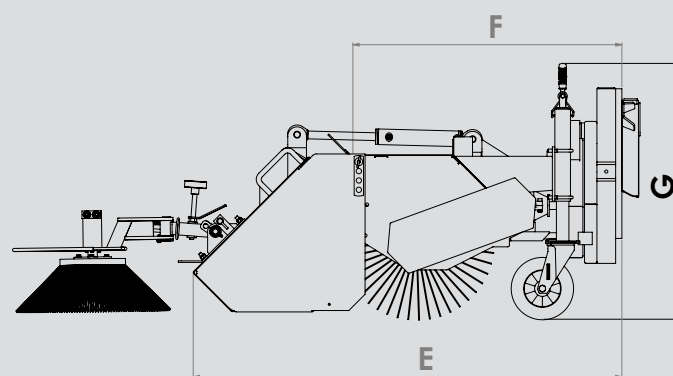
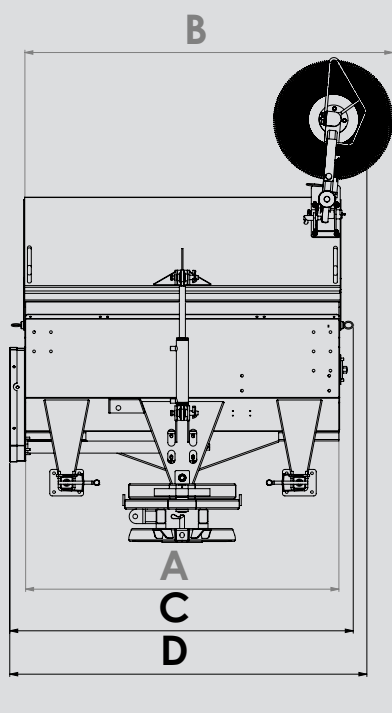

Item number	Description
<p><b>KM 13050 M-ABR 50</b> (without attachment frame)</p> 	<p><b>Sweeper mechanically driven</b> Working width 130 cm</p> <ul style="list-style-type: none"> <li>• Quick change axle</li> <li>• Combination sweeper roller included</li> <li>• Hydraulically swivelling left and right (1 x dw required)</li> <li>• Pendulum suspended</li> <li>• 2 height-adjustable wheels via spindles with thrust bearing</li> <li>• wheels 200 x 50 mm</li> <li>• Rubber spray flaps included</li> <li>• Including cardan shaft</li> <li>• Including parking support</li> </ul> <p><b>ABR 50 required</b></p>
<p><b>KM 14750 M-ABR 50</b> (without attachment frame)</p>	<p><b>Sweeper mechanically driven</b> Working width 147 cm For further description see KM 13050 M-ABR 50</p>
<p><b>KM 16550 M-ABR 50</b> (without attachment frame)</p>	<p><b>Sweeper mechanically driven</b> Working width 165 cm For further description see KM 13050 M-ABR 50</p>
<p><b>KM 13050 H-ABR 50</b> (without attachment frame)</p> 	<p><b>Sweeper hydraulically driven</b> Working width 165 cm</p> <ul style="list-style-type: none"> <li>• Hydraulically driven</li> <li>• internal orbital motor</li> <li>• Quick change axle</li> <li>• Combination sweeper roller included</li> <li>• Hydraulic left and right swivel (1 x dw required)</li> <li>• Pendulum suspended</li> <li>• 2 height-adjustable wheels via spindles with thrust bearing 200 x 50 mm</li> <li>• Rubber spray flaps</li> <li>• Supports included</li> </ul> <p><b>ABR 50 required</b></p>
<p><b>KM 14750 H-ABR 50</b> (without attachment frame)</p>	<p><b>Sweeper hydraulically driven</b> Working width 147 cm For further description see KM 13050 H-ABR 50</p>
<p><b>KM 16550 H-ABR 50</b> (without attachment frame)</p>	<p><b>Sweeper hydraulically driven</b> Working width 165 cm For further description see KM 13050 H-ABR 50</p>
<p><b>Attachment frame for compact tractor sweepers</b> When ordering, specify exact carrier vehicle type and attachment type.</p>	
<p><b>ABR 50 KD-...</b></p>	<p><b>Attachment frame for dome-triangle mounting</b></p>
<p><b>ABR 50 DP-...</b></p>	<p><b>Attachment frame three-point linkage Cat I and II</b></p>
<p><b>ABR 50 FM-...</b></p>	<p><b>Attachment frame area mower (2-point)</b> (not available for all models)</p>

Description	Compatible with sweeper	KM 13050
<b>Options/Accessories</b>		
<b>Dirt collection tank</b> <ul style="list-style-type: none"> <li>Including hydraulic container emptying</li> <li>Container made of sheet steel</li> <li>Plug-in mounted</li> </ul>		Item number SSB 13050 B
<b>Attachment side broom 50 cm</b> <ul style="list-style-type: none"> <li>Hydraulically driven</li> <li>With mounting plate</li> <li>Separate oil supply for the side broom on the sweeper</li> <li>Infinitely adjustable via control valve</li> <li>Separately switchable</li> <li>Hard disc broom</li> <li><b>Suitable for all KM ... M (mechanical drive)</b></li> </ul>		Item number ASH 50 KM 4050 M
<b>Attachment side broom 50 cm</b> <ul style="list-style-type: none"> <li><b>Suitable for all KM ... H (hydraulic drive)</b></li> </ul> For further description see ASH 50KM 4050 M		Item number ASH 50 KM 4050 H
<b>Water sprinkler 100 litres</b> <ul style="list-style-type: none"> <li>Electric submersible pump 12 V</li> <li>Spray nozzles for even distribution</li> <li>Suitable for three-point attachment KAT 1</li> </ul> <b>12 V plug-in coupling required on carrier vehicle</b>		Item number WAS 100 KAT 1
<b>Water sprinkler 100 litres</b> <ul style="list-style-type: none"> <li>Electric submersible pump 12 V</li> <li>Spray nozzles for even distribution</li> <li>Water barrel mounted on the KM</li> </ul> <b>12 V plug-in coupling required on carrier vehicle</b>		Item number WAS 100 AUF-KM 50
<b>Water sprinkler 200 litres</b> <ul style="list-style-type: none"> <li>Electric submersible pump 12 V</li> <li>Spray nozzles for even distribution</li> <li>Water barrel in rear three-point linkage</li> </ul> <b>12 V plug-in coupling required on carrier vehicle</b>		Item number WAS 200 KAT I
<b>Running wheels 180 x 80 mm</b> <ul style="list-style-type: none"> <li>Including heavy turntable, instead of the standard wheels</li> </ul>		Item number MP-RD 180 X 80
<b>Electromagnetic valve</b> <ul style="list-style-type: none"> <li>For installation in the sweeper, thus only 1 dw required</li> <li>Function: swivel and sweeper drive</li> </ul>		Item number EMV-KM 50
<b>Supports for sweeping roller diameter 40 or 50 cm</b> <ul style="list-style-type: none"> <li>With castors</li> <li>For easier mounting and dismantling of the sweeper</li> <li>For storage of the sweeper</li> </ul>		Item number AST 4050 LR
<b>Sprocket</b> <ul style="list-style-type: none"> <li>For increasing the speed when sweeping snow</li> </ul>		Item number S1138
<b>Red-white marker lights</b>		Item number BGL-KM 50
<b>Set of warning flags with holder</b>		Item number WA-FLAG-KM 50

KM 14750	KM 16550
SSB 14750 B	SSB 16550 B
ASH 50 KM 4050 M	ASH 50 KM 4050 M
ASH 50 KM 4050 H	ASH 50 KM 4050 H
WAS 100 KAT 1	WAS 100 KAT 1
WAS 100 AUF-KM 50	WAS 100 AUF-KM 50
WAS 200 KAT I	WAS 200 KAT I
MP-RD 180 X 80	MP-RD 180 X 80
EMV-KM 50	EMV-KM 50
AST 4050 LR	AST 4050 LR
S1138	S1138
BGL-KM 50	BGL-KM 50
WA-FLAG-KM 50	WA-FLAG-KM 50