

Sweepers for front and rear mounting

For tractors, farm tractors, forklifts, wheel loaders and municipal vehicles

KM 52

Working widths

125/150/190/225 cm

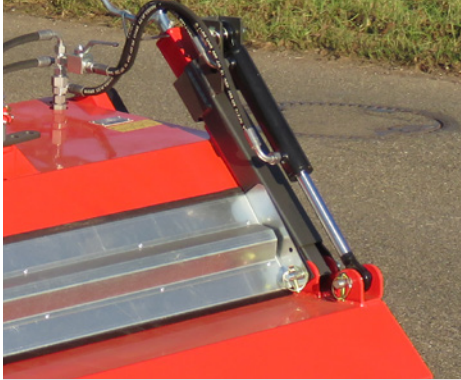
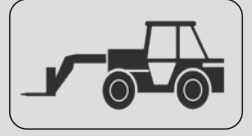
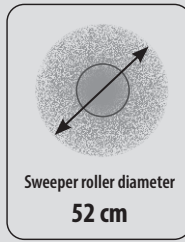

Hydraulic
Container emptying

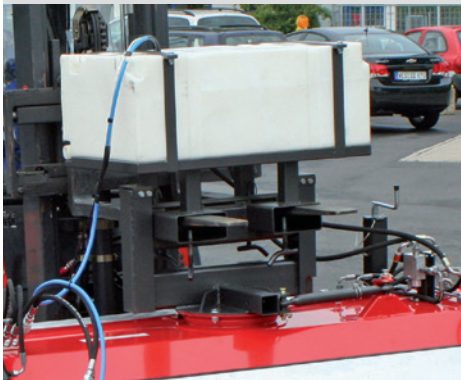

Water sprinkler system

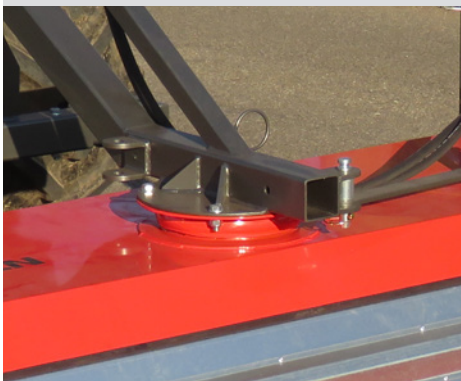

Slewing ring for
lateral swivelling
(hydraulic adjustment optional)



Internal
Hydraulic motor
and chain box



Sweeping roller versions

Combination sweeper roller (1), poly-corrugated wire sweeper roller (2), Dirt sweeper roller (3), Snow sweeper roller (4)

Other roller types for different applications possible.

Attachment frame can be used for
front and rear area

Stepless adjustment
of the sweeping brush

Slewing ring

Stopcock for
sweeping with open
collection container

Chain case

Collecting tank
made of steel
(option)

Hydraulic
Container emptying



FACTS

Use

Sweeper roller types

- **Combination sweeper roller (standard)**
For over 90% of all applications
- **Poly-corrugated wire sweeping roller (Option)**
For high levels of stubborn dirt, e.g. moss etc.
- **Dirt sweeping roller (Option)**
Due to higher bristle content suitable for greater soiling
- **Snow sweeping roller (Option)**
A special bristle arrangement with a larger the snow is optimally removed.

Practical accessories

- **Dirt collection container**
The sweepings are collected in one operation
- **Rubber spray flap**
To reduce flying dirt particles
- **Side broom**
For collecting dirt even in side areas, z. e.g. kerb gutters etc.
- **Parking supports**
For longer storage so as not to damage the sweeping roller
- **Hydraulic swivelling device**
For swivelling the machine on both sides

Stopcock for sweeping with open collection container

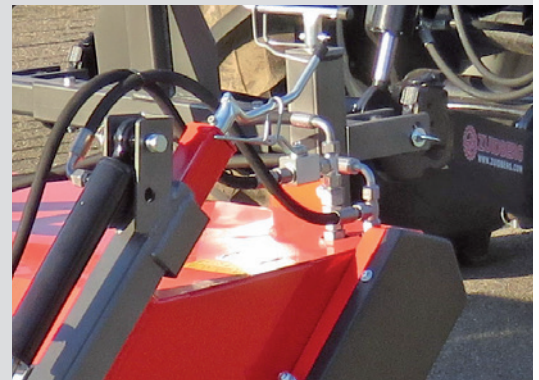

Hydraulically driven side brush with collision safety device and tool-free angle adjustment







Height adjustment

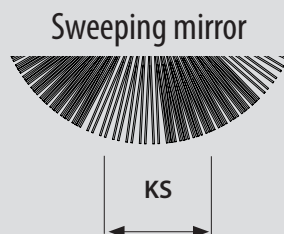
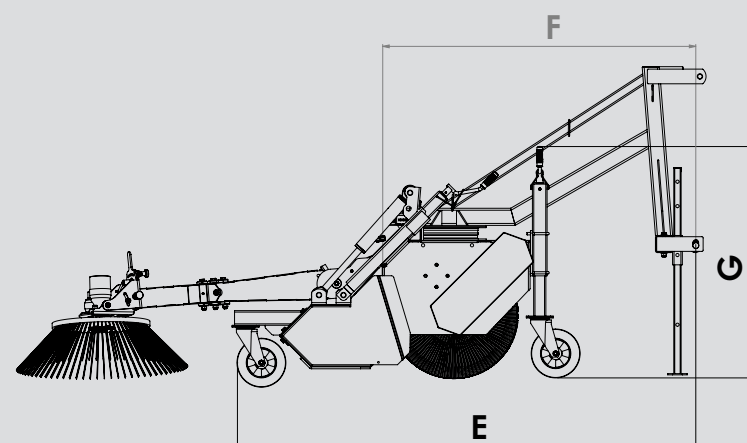
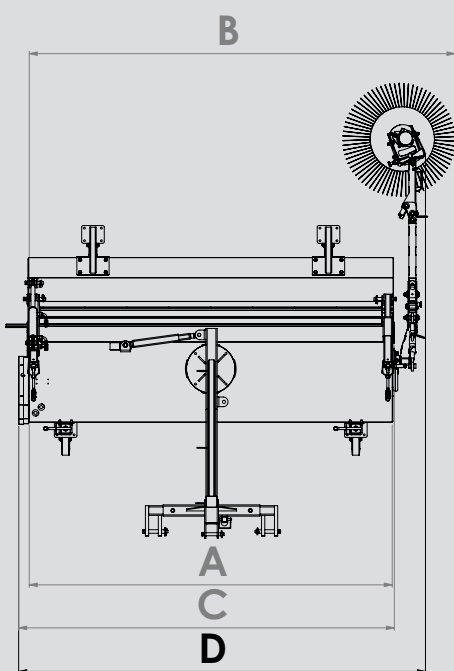

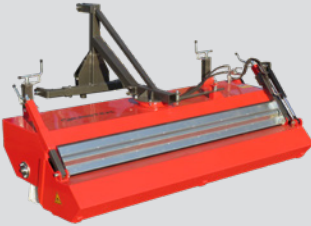
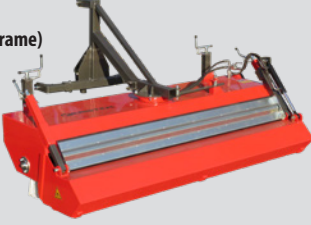
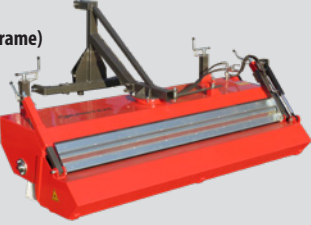
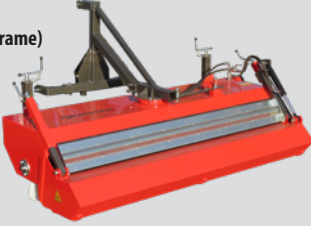
Measurements	KM 12552 H	KM 15052 H	KM 19052 H	KM 22552 H
A: Working width straight; without side brush [cm]	125	150	190	225
B: Working width straight; with side brushes [cm]	165	190	230	265
Working width diagonal [cm]	118	140	172	204
C: Straight passage width; without side brushes [cm]	133	158	198	233
D: Straight passage width; with side brushes [cm]	152	177	217	252
Passage width sloping; without SSB [cm]	159	178	215	247
E: Length; Including SSB; with attachment frame [cm]	188	188	188	188
F: Length; without SSB; with attachment frame [cm]	128	128	128	128
G: Height; without attachment frame [cm]	95	95	95	95
Brush diameter [cm]	52	52	52	52
Swivel angle [degrees]	25	25	25	25
Sweeping mirror [cm]	8-10	8-10	8-10	8-10
Weights				
Basic unit [kg]	155	166	180	195
Collecting container [kg]	40	55	60	68
Side brushes [kg]	40	40	40	40
Water sprinkler 100 ltr ; full tanks [kg]	118	118	118	118
Water sprinkler 200 ltr ; full tanks [kg]	218	218	218	218
Volume				
Collecting tank [litr]	85	102	130	150
Water sprinkler capacity [litr]	100	100	100	100
Capacity				
Oil volume [litr/min] at 180 bar	35	35	35	35

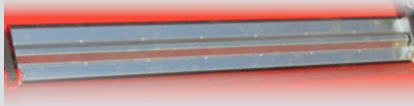
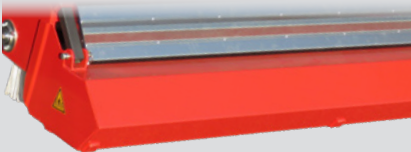

Item number	Description
<p>KM 12552 H (without attachment frame)</p> 	<p>Sweeper 125 cm working width Sweeping roller diameter 52 cm</p> <ul style="list-style-type: none"> • hydraulically driven • Internal orbital motor • Drive via duplex chain • 2 height-adjustable running wheels 200 x 50 mm via spindles with thrust bearing • Mechanically swivelling left and right via ball slewing ring Ø 300 mm • Including combi-sweeping roller • Including three-way cock for free sweeping with open collection container • Including parking support <p>ABR 52 ... required</p>
<p>KM 15052 H (without attachment frame)</p> 	<p>Sweeper 150 cm working width Sweeping roller diameter 52 cm</p> <p>For further description see art. no.: KM 12552 H</p>
<p>KM 19052 H (without attachment frame)</p> 	<p>Sweeper 190 cm working width Sweeping roller diameter 52 cm</p> <p>For further description see art. no.: KM 12552 H</p>
<p>KM 22552 H (without attachment frame)</p> 	<p>Sweeper 225 cm working width Sweeping roller diameter 52 cm</p> <p>For further description see art. no.: KM 12552 H</p>
Attachment frame	
ABR 52 HT-...	Attachment frame with height compensation for Hoftrac
ABR 52 HECK	Attachment frame for rear pivot point cat I and II
ABR 52 FRONT	Attachment frame for front three-point linkage cat I and II
ABR 52 EURO	Attachment frame with height compensation for Euro receptacle
<p>ABR 52 GS-HA</p> <ul style="list-style-type: none"> • Third wheel (art. no. LR-SSB-KM or MP-LR-ABR 52 KPL) required 	<p>Attachment frame with height compensation for forklift tines</p>
ABR 52 KD	Attachment frame for dome triangles
ABR 52 KUB	Attachment frame for Kubota front loader
ABR 52 JD	Attachment frame for John Deere front loader
<p>Sweeper with hydraulic drive: A control valve and a pressureless return flow into the tank are required on the carrier vehicle. The recommended volume flow is 35 L/min. at 180 bar pressure. Please state the volume flow when ordering!</p>	

Description	Compatible with sweeper	KM 12552 H		
Options/Accessories				
Splash guard <ul style="list-style-type: none"> Sheet metal apron long Rubber spray flap Mounting material included 		<table border="1"> <tr> <td data-bbox="954 212 1129 255">Item number</td> <td data-bbox="1129 212 1592 255">SPL 12552</td> </tr> </table>	Item number	SPL 12552
Item number	SPL 12552			
Dirt collection container <ul style="list-style-type: none"> Plug-in mounted Including hydraulic tank emptying 		<table border="1"> <tr> <td data-bbox="954 430 1129 472">Item number</td> <td data-bbox="1129 430 1592 472">SSB 12552</td> </tr> </table>	Item number	SSB 12552
Item number	SSB 12552			
Wheels for collection containers (from 150 cm working width 2 pieces recommended)		<table border="1"> <tr> <td data-bbox="954 638 1129 680">Item number</td> <td data-bbox="1129 638 1592 680">LR-SSB-KM 52</td> </tr> </table>	Item number	LR-SSB-KM 52
Item number	LR-SSB-KM 52			
Attachable side broom 70 cm broom diameter on the right <ul style="list-style-type: none"> Hydraulically driven, infinitely variable Start-up safety device Mounting plate 		<table border="1"> <tr> <td data-bbox="954 743 1129 786">Art.-Nr.</td> <td data-bbox="1129 743 1592 786">ASH 7052 R</td> </tr> </table>	Art.-Nr.	ASH 7052 R
Art.-Nr.	ASH 7052 R			
Attachable side broom 70 cm broom diameter left <ul style="list-style-type: none"> Hydraulically driven, infinitely variable Start-up safety device Mounting plate 		<table border="1"> <tr> <td data-bbox="954 952 1129 994">Item number</td> <td data-bbox="1129 952 1592 994">ASH 7052 L</td> </tr> </table>	Item number	ASH 7052 L
Item number	ASH 7052 L			
Water sprinkler <ul style="list-style-type: none"> Water tank 100 litres, for mounting on the sweeper Nozzle bar for sweeper installation Electric submersible pump 12 volts 		<table border="1"> <tr> <td data-bbox="954 1160 1129 1202">Item number</td> <td data-bbox="1129 1160 1592 1202">WAS 100 KM 52</td> </tr> </table>	Item number	WAS 100 KM 52
Item number	WAS 100 KM 52			
Water sprinkler <ul style="list-style-type: none"> Water tank 200 litres, for mounting on the sweeper Nozzle bar for sweeper installation Electric submersible pump 12 volts <p>Use only when mounted on forklift</p>		<table border="1"> <tr> <td data-bbox="954 1368 1129 1411">Item number</td> <td data-bbox="1129 1368 1592 1411">-</td> </tr> </table>	Item number	-
Item number	-			
Hydraulic slewing device <ul style="list-style-type: none"> For swivelling the machine on both sides 		<table border="1"> <tr> <td data-bbox="954 1576 1129 1619">Item number</td> <td data-bbox="1129 1576 1592 1619">S1010</td> </tr> </table>	Item number	S1010
Item number	S1010			
Impeller on attachment frame (200 x 50 mm) <ul style="list-style-type: none"> Surcharge for additional wheel on attachment frame Height adjustment via spindle 		<table border="1"> <tr> <td data-bbox="954 1682 1129 1724">Item number</td> <td data-bbox="1129 1682 1592 1724">MP-LR-ABR 52 KPL</td> </tr> </table>	Item number	MP-LR-ABR 52 KPL
Item number	MP-LR-ABR 52 KPL			
Red-white marker lights		<table border="1"> <tr> <td data-bbox="954 1787 1129 1830">Item number</td> <td data-bbox="1129 1787 1592 1830">BGL-KM 52</td> </tr> </table>	Item number	BGL-KM 52
Item number	BGL-KM 52			
Set of warning flags with holder		<table border="1"> <tr> <td data-bbox="954 1892 1129 1935">Item number</td> <td data-bbox="1129 1892 1592 1935">WA-FLAG-KM 52</td> </tr> </table>	Item number	WA-FLAG-KM 52
Item number	WA-FLAG-KM 52			

KM 15052 H	KM 19052 H	KM 22552 H
SPL 15052	SPL 19052	SPL 22552
Cannot be used with dirt collection container!		
SSB 15052	SSB 19052	SSB 22552
LR-SSB-KM 52	LR-SSB-KM 52	LR-SSB-KM 52
ASH 7052 R	ASH 7052 R	ASH 7052 R
ASH 7052 L	ASH 7052 L	ASH 7052 L
WAS 100 KM 52	WAS 100 KM 52	WAS 100 KM 52
-	WAS 200 KM 52 (for forklift only)	WAS 200 KM 52 (for forklift only)
S1010	S1010	S1010
MP-LR-ABR 52 KPL	MP-LR-ABR 52 KPL	MP-LR-ABR 52 KPL
BGL-KM 52	BGL-KM 52	BGL-KM 52
WA-FLAG-KM 52	WA-FLAG-KM 52	WA-FLAG-KM 52